Renault

Select the model:

Model Clio Sagem before 1999

Model Clio Sagem after 1999

Model Clio Jaeger before 1999

Model Clio Jaeger after 1999

Model Espace before 2000

Model Espace 2000

Model Kangoo before 1999

Model Kangoo ab 1999

Model Laguna Sagem after 1999

Model Laguna Jaeger

Model Megane / Scenic Sagem before 1999

Model Megane / Scenic Sagem after 1999

Model Megane / Scenic Jaeger before 1999

Model Megane / Scenic Jaeger after 1999

Model Safrane

Model Twingo

Model Clio Sagem before 1999

Use this board and clip:

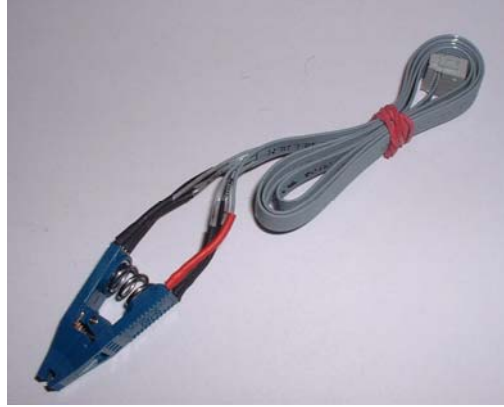
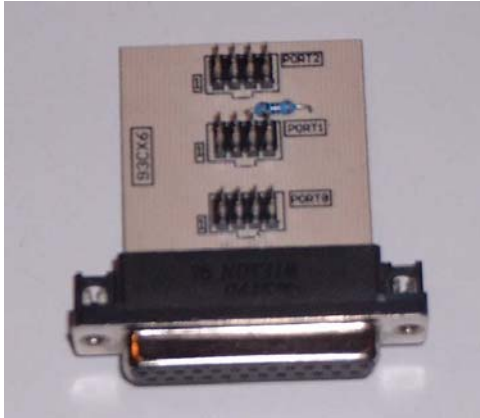

- Remove the cluster and open it.
- Look for the silver chrystal and join its contacts.
- Look for the 8 pin chip 93C46.
- Connect the clip to port 1.
- Put the clip on the chip 93C46 (red on pin 1).
- Select the menu **Renault-Clio II-Sagem**
- The Tacho Universal shows you the old value.
- Select the menu **Adjust KM.**
- Enter the new value.
- Verify the new value with **OK.**

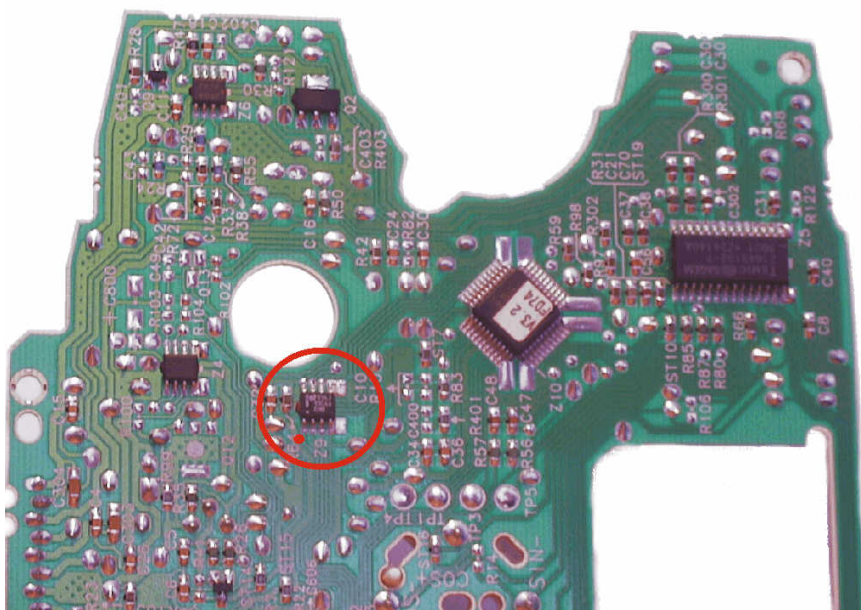

Model Clio Sagem after 1999

The instrument looks like this:



This instrument has to be sent to us or can be clocked with a separate manual. It takes about 3 days time.

Model Clio Jaeger before 1999

Use this board and clip:

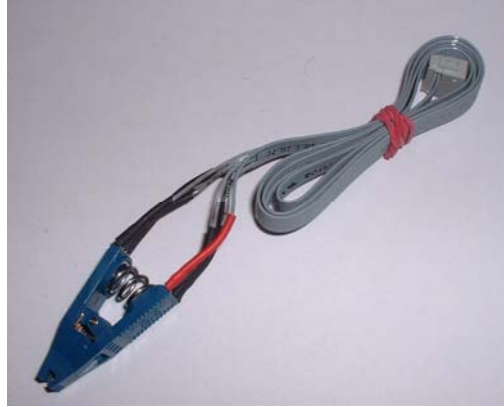
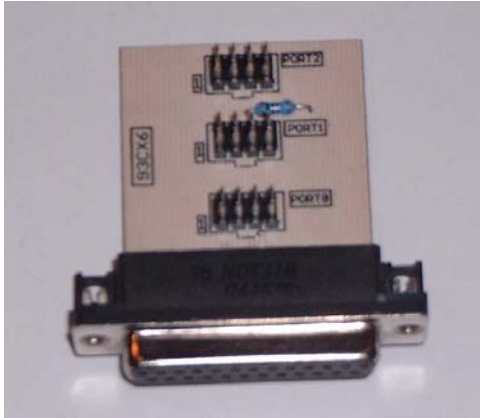

- Remove the cluster and open it.
- Look for the silver crystal and join its contacts.
- Look for the 8 pin chip 93C46.
- Connect the clip to port 1.
- Put the clip on the chip 93C46 (red on pin 1).
- Select the menu **Renault-Clio II-Jaeger C46**
- The Tacho Universal shows you the old value.
- Select the menu **Adjust KM.**
- Enter the new value.
- Verify the new value with **OK.**

Model Clio Jaeger after 1999

Use the 908-Plug:



- Remove the cluster and open it. You have to pull off the needles and unclip the motors carefully.
- Look for the processor as shown in the picture.
 - Version 1 is for instruments without rpm-instrument
 - Version V is for instruments with rpm-instrument
- Connect the cables as shown in the picture.
- Connect the plug with the Tacho Universal.
- Select the menu **Renault-Clio II- Jaeger 908**
- The Tacho Universal shows you the old value.
- Enter the new value.
- Verify the new value with **OK**.

Version 1

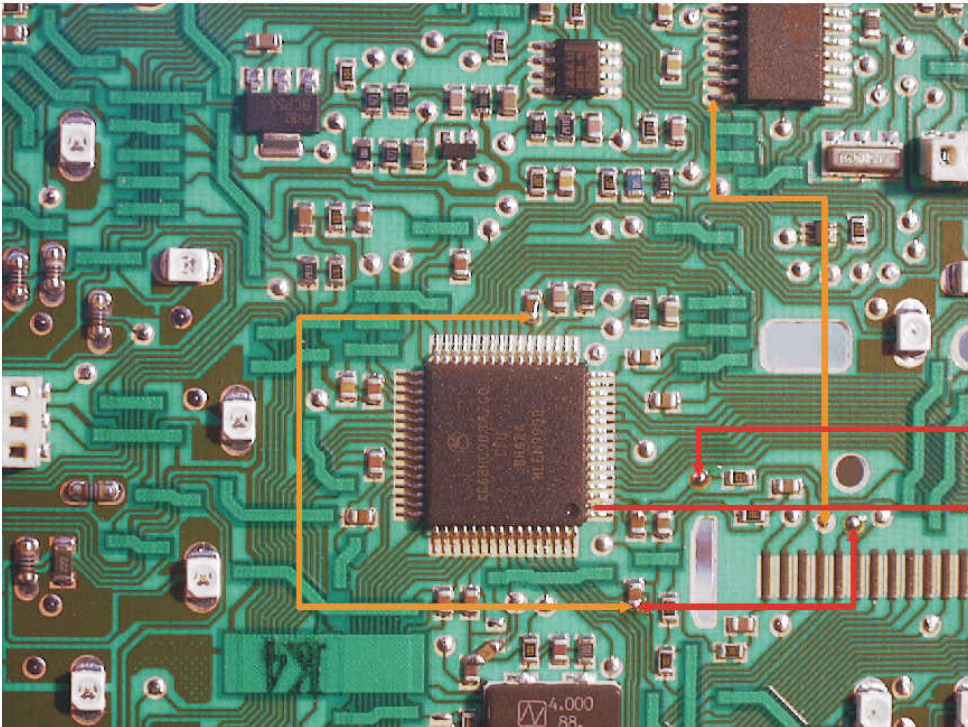

cable 3
lift pin
cable 2

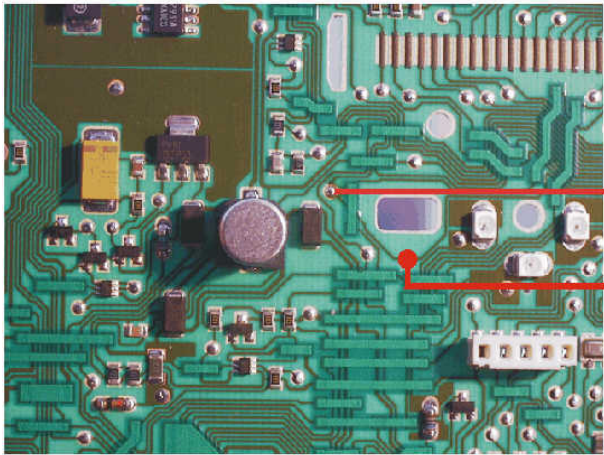

cable 1
for Kangoo cable 1 is here

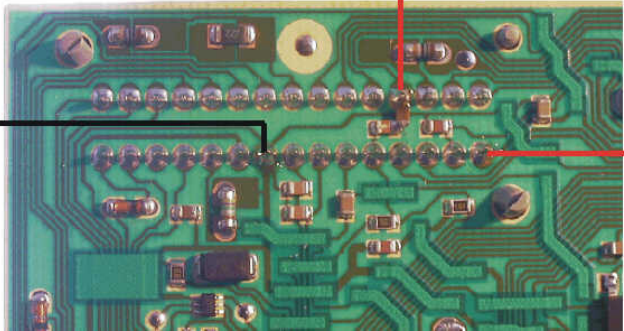

black (gnd)

red (+12V)

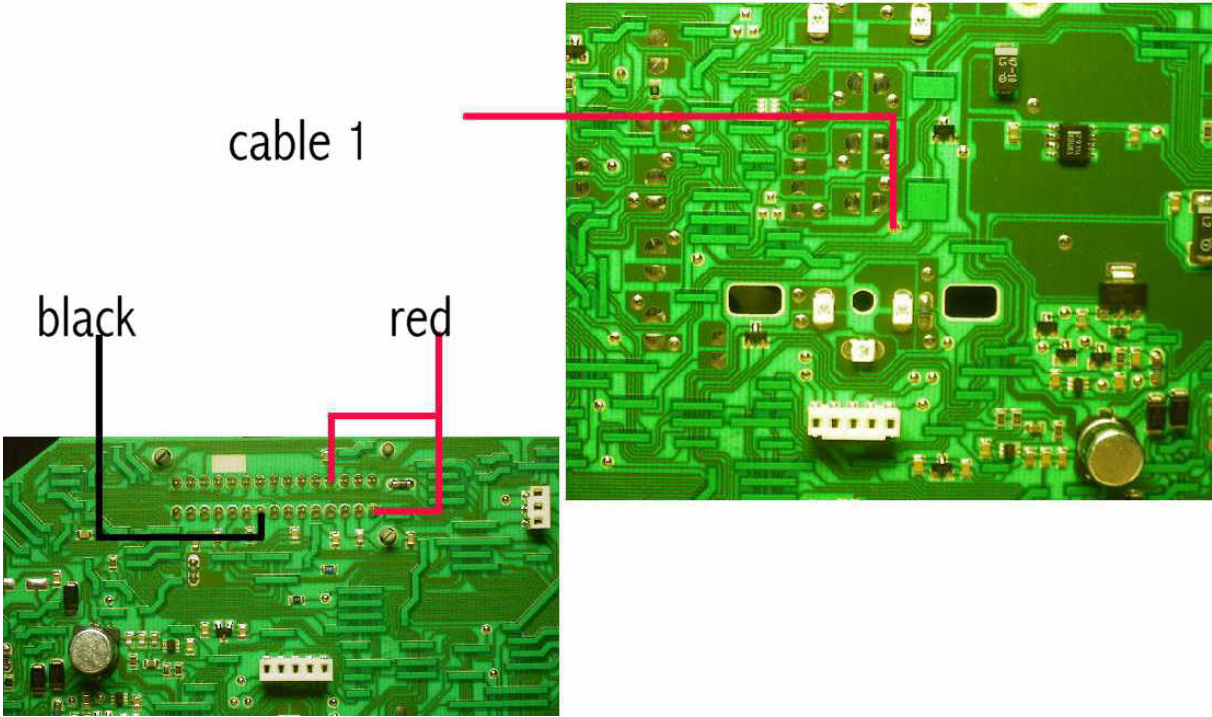
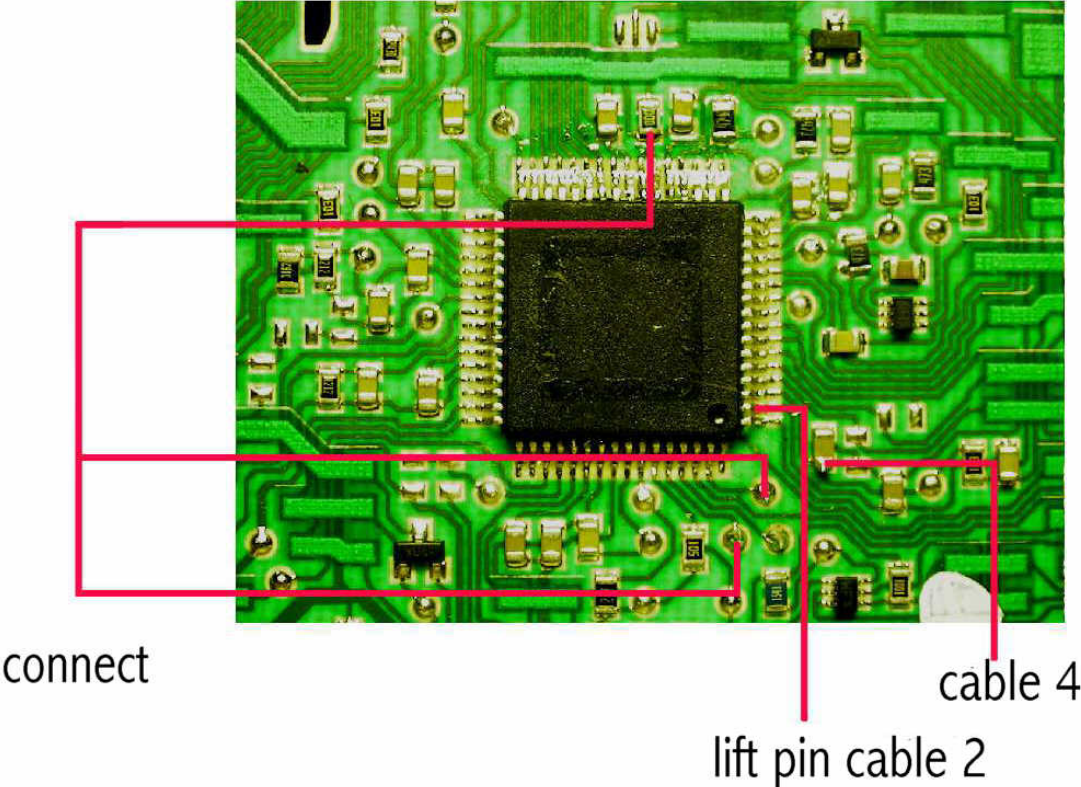

Model Espace before 2000

You have to send us this instrument.

Model Espace 2000

Use the 908-Plug:



- Remove the cluster and open it.
- Connect the cables as shown in the picture.
- Connect the 908-Plug with the Tacho Universal.
- Select the menu **Renault-Espace 2000-Tacho**
- You need not enter a new value, programming will be done automatically.
- Do not put the instrument back in now.

lift pin
cable 1

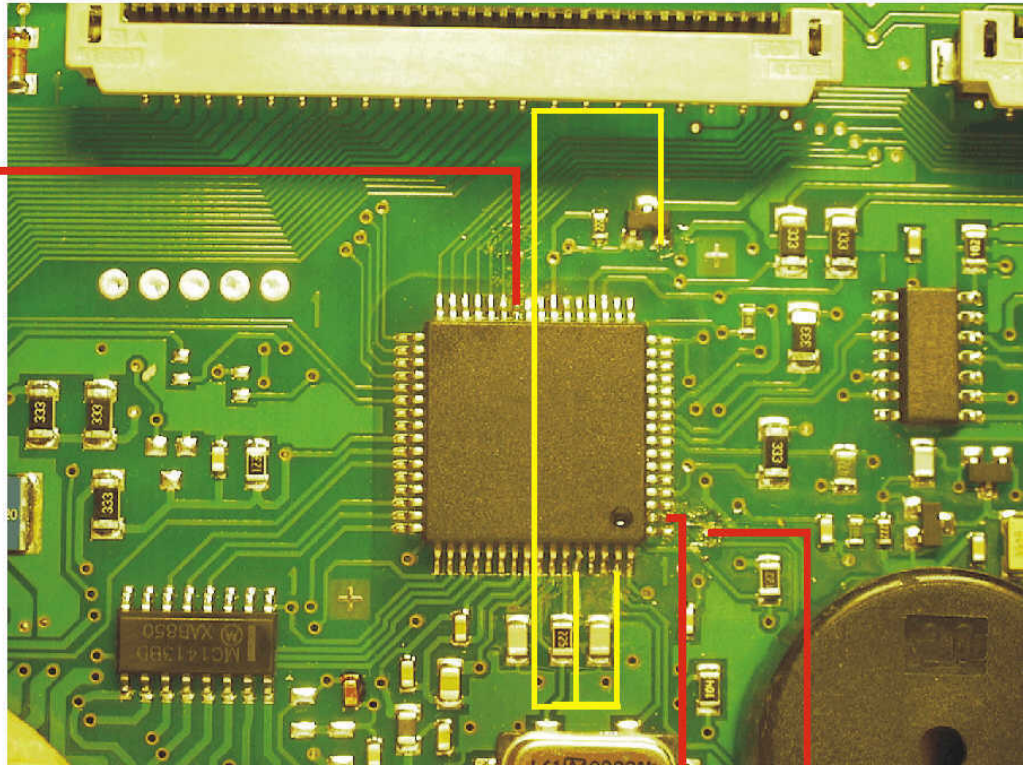

lift and connect yellow pins!

lift pin cable 2

cable 3

red (+12 V)

black (gnd)

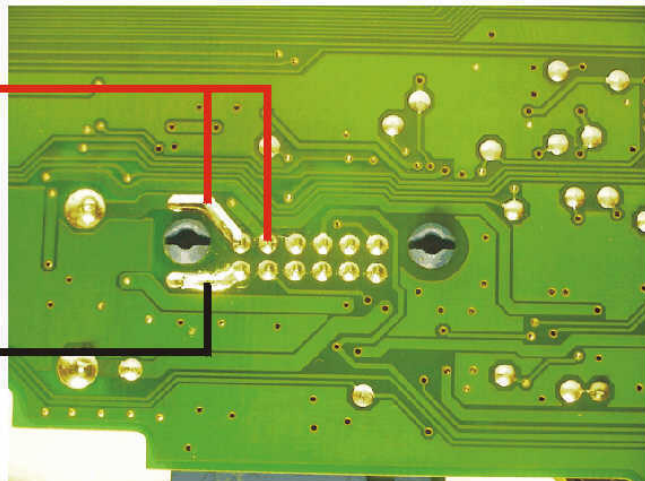

- Remove the BCU and open it.
- Connect the cables as shown in the picture.
- Connect the 908-plug with the Tacho Universal.
- Select the menu **Renault-Espace 2000-Body Controller**
- The Tacho Universal shows you the old value.
- Enter the new value. Verify the new value with **OK**.
- Now put back in the BCU first, then the instrument.

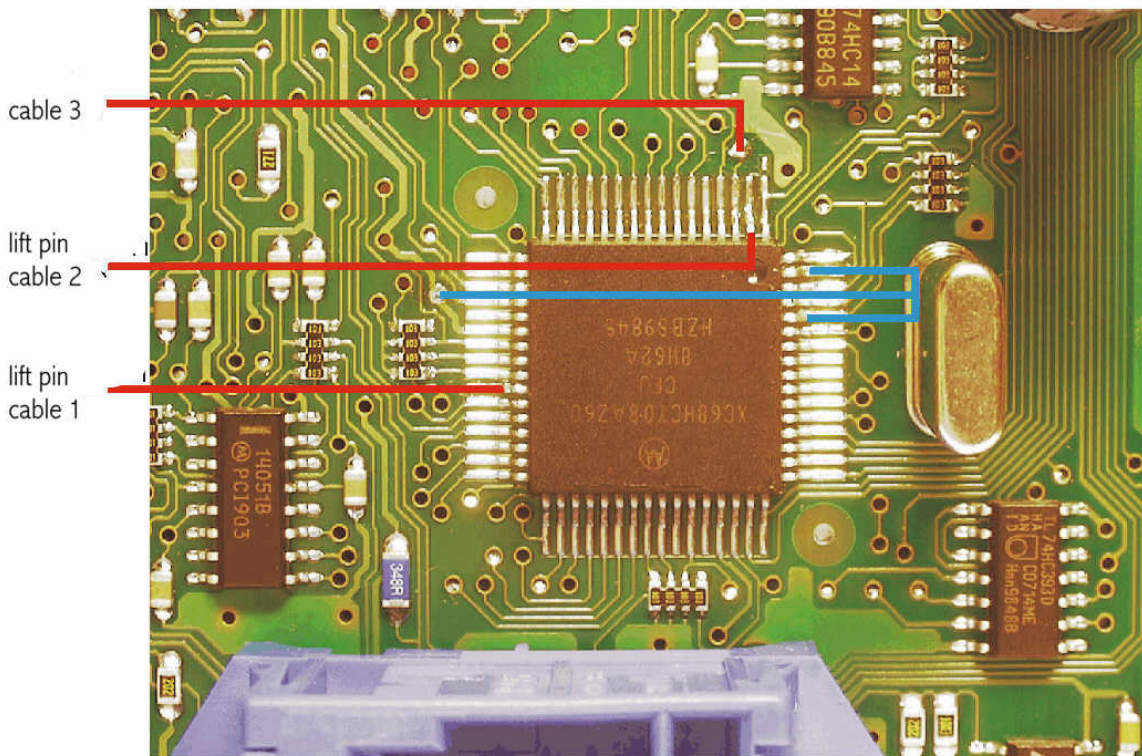

lift and connect blue pins!

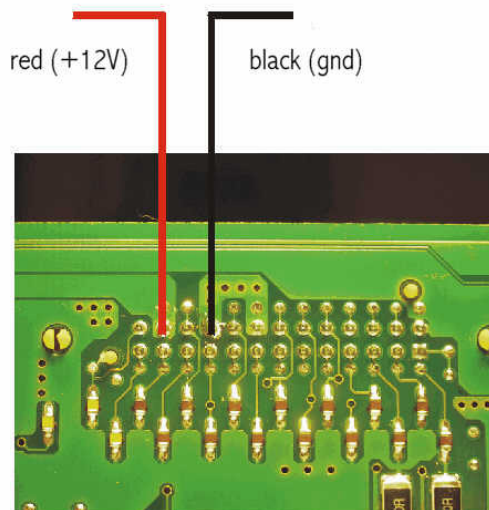
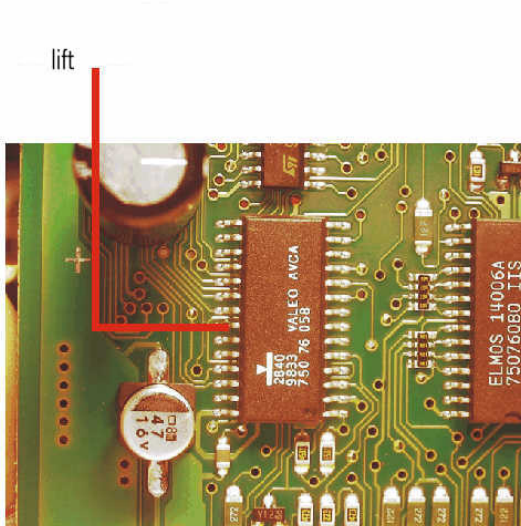

Model Kangoo before 1999

Use this board and clip:

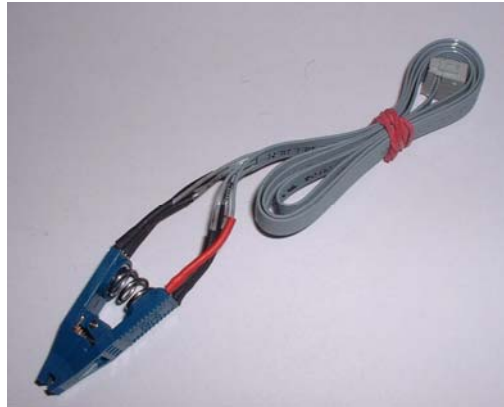
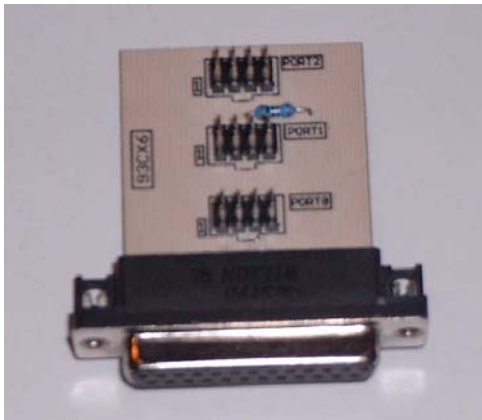

- Remove the cluster and open it.
- Look for the silver crystal and join its contacts.
- Look for the 8 pin chip 93C46.
- Connect the clip to port 1.
- Put the clip on the chip 93C46 (red on pin 1).
- Select the menu **Renault-Kangoo**
- The Tacho Universal shows you the old value.
- Select the menu **Adjust KM.**
- Enter the new value.
- Verify the new value with **OK.**

Model Kangoo ab 1999

Use the 908-Plug:



- Remove the cluster and open it. You have to pull off the needles and unclip the motors carefully.
- Look for the processor as shown in the picture.
- Connect the cables as shown in the picture.
- Connect the plug with the Tacho Universal.
- Select the menu **Renault-Clio II- Jaeger 908**
- The Tacho Universal shows you the old value.
- Enter the new value.
- Verify the new value with **OK**.

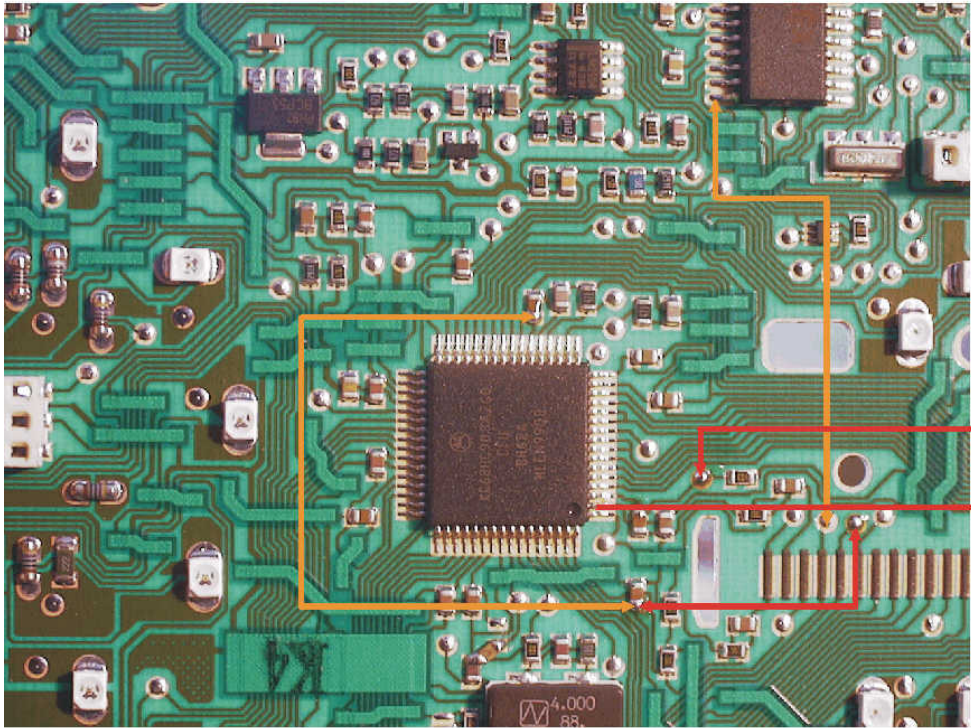

cable 3

lift pin
cable 2

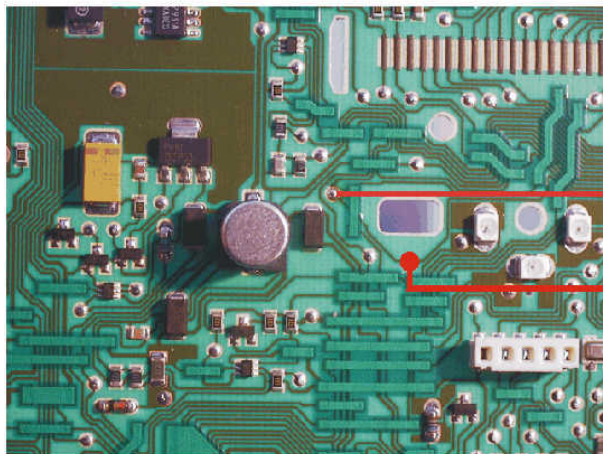

cable 1

for Kangoo cable 1 is here

red (+12V)

black (gnd)

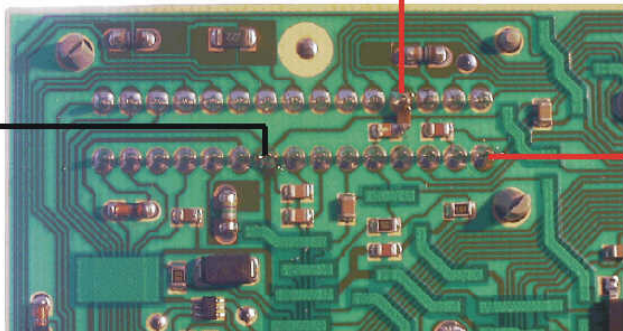

Model Laguna Sagem after 1999

Use this board and clip:

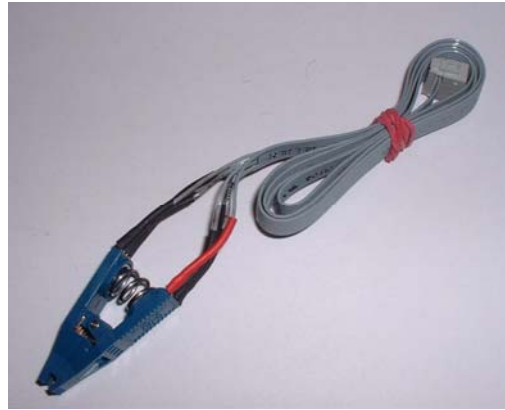
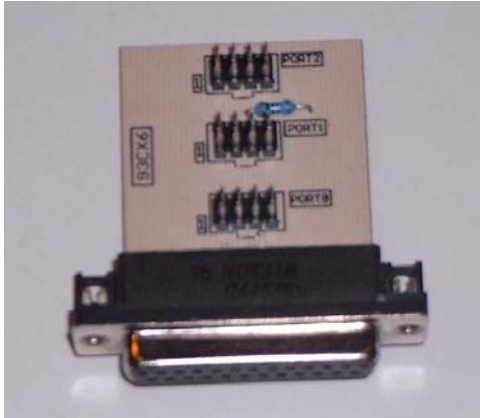

- Remove the cluster and open it.
- Look for the 8 pin chip 93C46.
- Look for the silver chrystral and join its contacts.
- Connect the clip to port 1.
- Put the clip on the chip 93C46 (red on pin 1).
- Select the menu **Renault-Laguna 99**
- The Tacho Universal shows you the old value.
- Select the menu **Adjust KM.**
- Enter the new value.
- Verify the new value with **OK.**

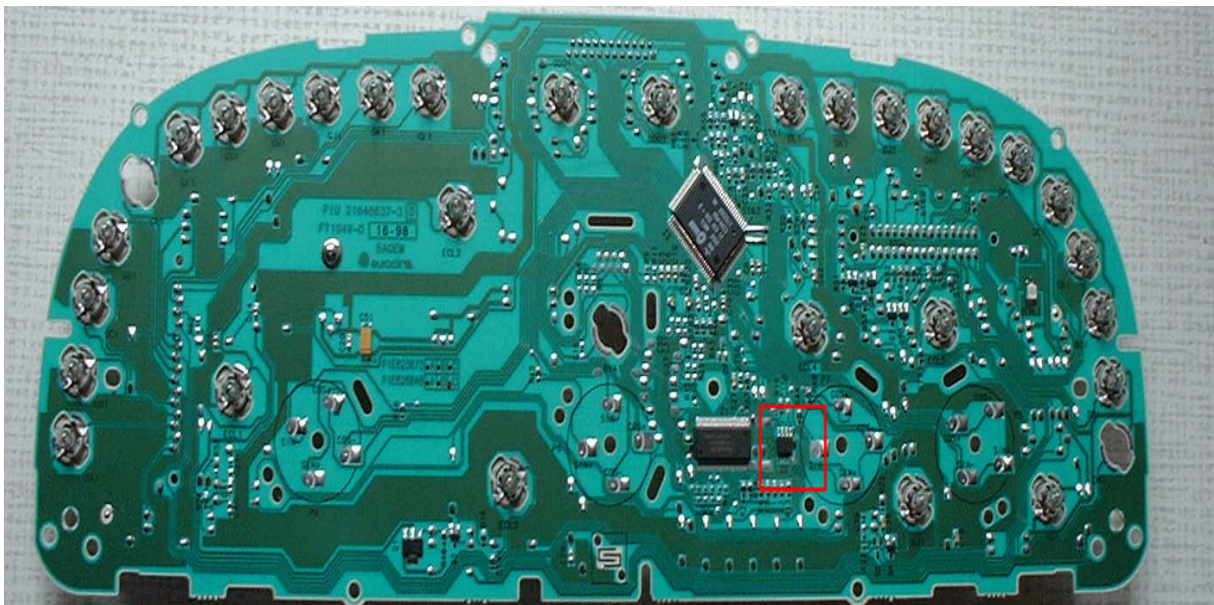

Model Laguna Jaeger

You have to send us this instrument.

Model Megane / Scenic Sagem before 1999

Use this board and clip:

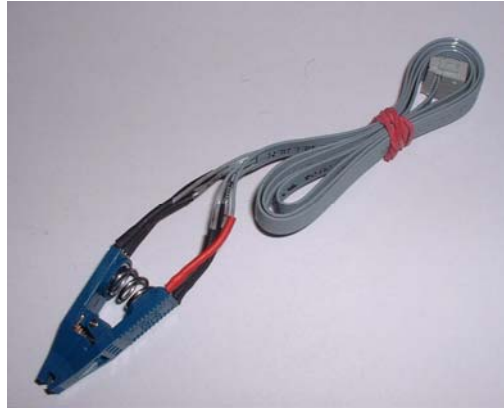
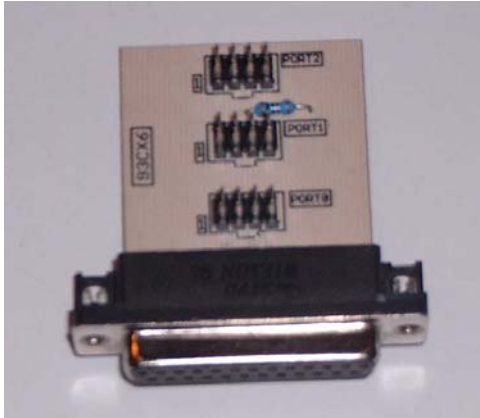

- Remove the cluster and open it.
- Look for the 8 pin chip 93C46.
- Look for the silver chrystal and join its contacts.
- Connect the clip to port 1.
- Put the clip on the chip 93C46 (red on pin 1).
- Select the menu **Renault-Megane- Sagem 1 oder Sagem 2**
- The Tacho Universal shows you the old value.
- Select the menu **Adjust KM.**
- Enter the new value.
- Verify the new value with **OK.**

Model Megane / Scenic Sagem after 1999

The instrument looks like this:



This instrument has to be sent to us or can be clocked with a separate manual. It takes about 3 days time.

Model Megane / Scenic Jaeger before 1999

Use the Megane/206-Plug:



- Remove the cluster.
- Remove the white cover on the rear side.
- Look for the processor as shown in the picture.
- Connect the cables as shown in the picture.
- Connect the plug with the Tacho Universal.
- Select the menu **Renault-Megane-Jaeger**
- The Tacho Universal shows you the old value.
- Enter the new value.
- Verify the new value with OK.

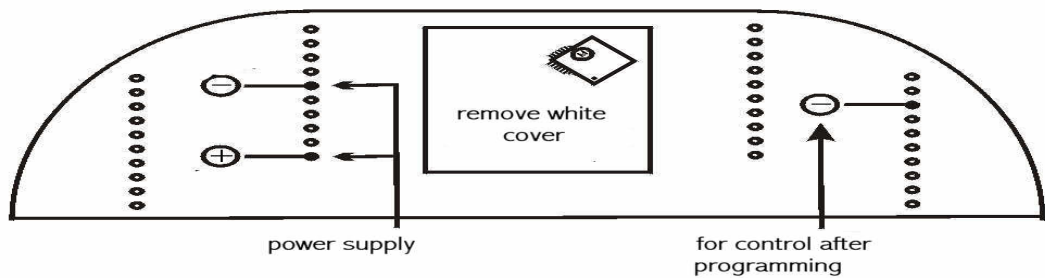

- ⊖
black (gnd)
- cut track of pin 5
- green to pin 5
- blue

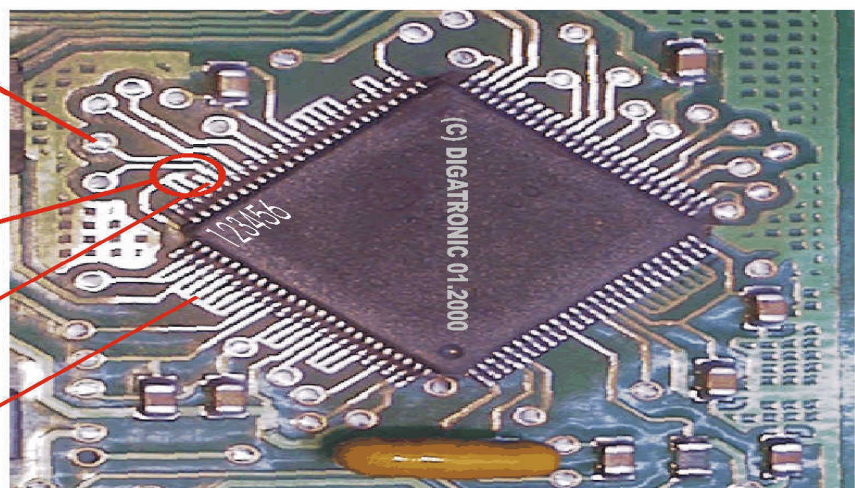

Model Megane / Scenic Jaeger after 1999

Use the 908-Plug:



- Remove the cluster and open it. You have to pull off the needles and carefully unclip the motors.
- Look for the processor.
- Connect the cables as shown in the picture, depending on what version it is.
- Connect the plug with the Tacho Universal.
- Select the menu **Renault-Megane- Jaeger 908**
- The Tacho Universal shows you the old value.
- Enter the new value.
- Verify the new value with **OK**.

Version 1

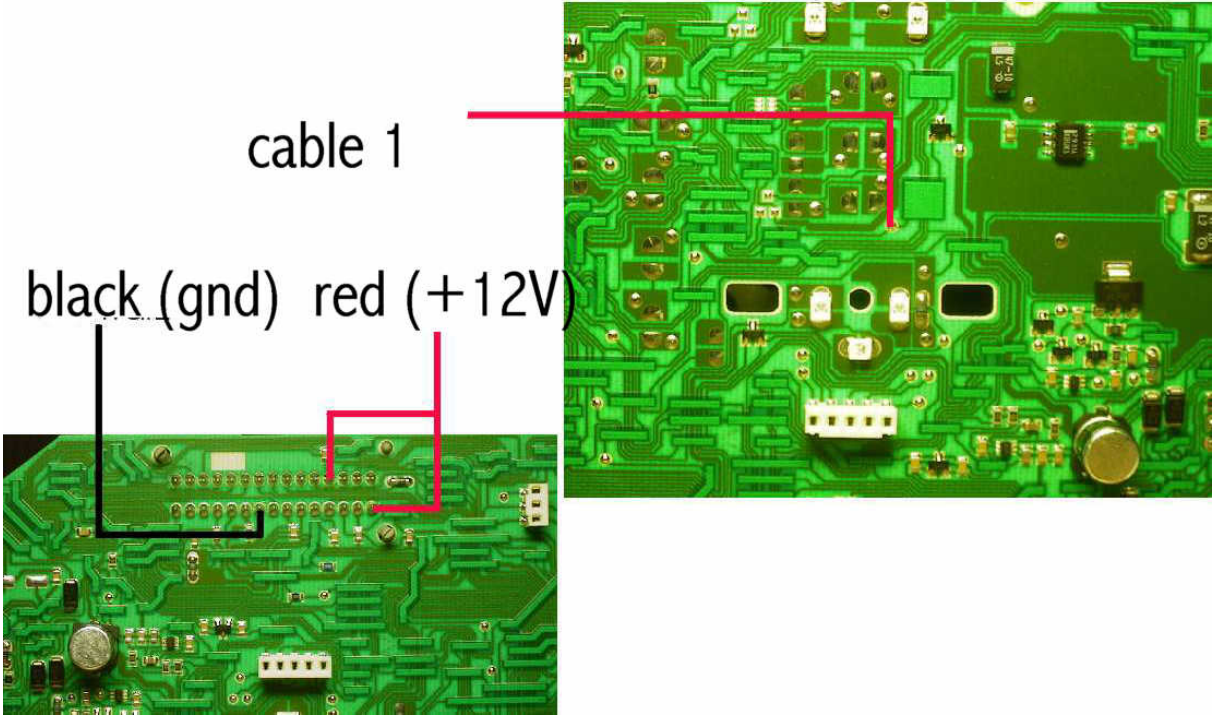
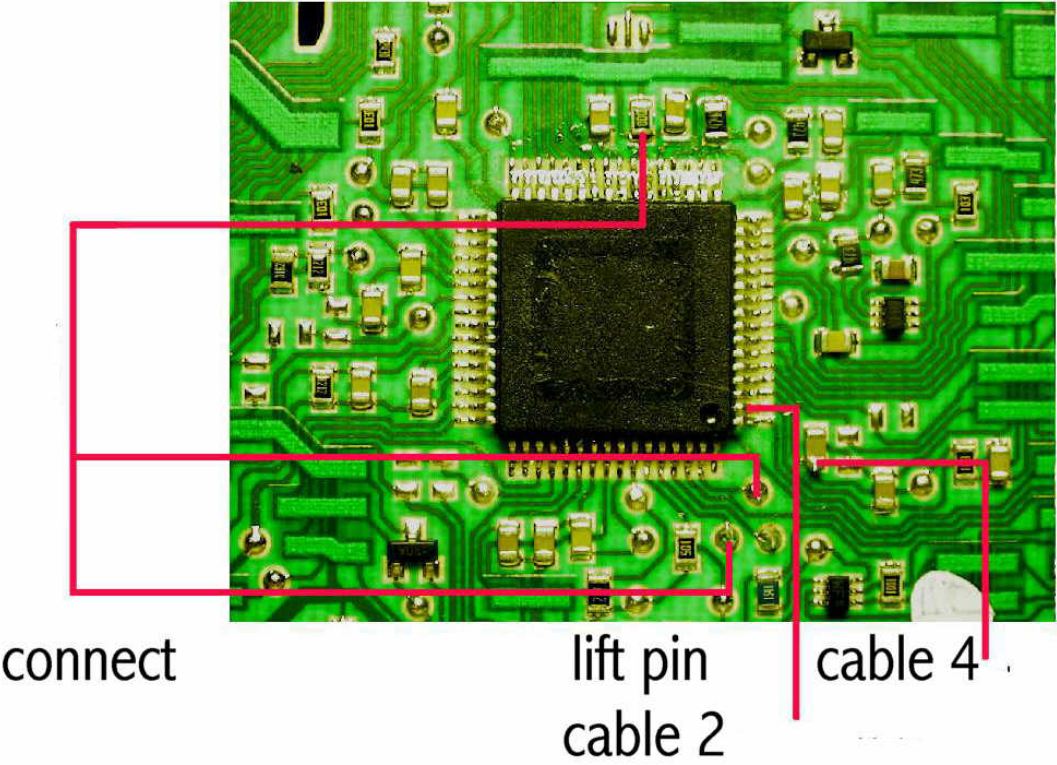

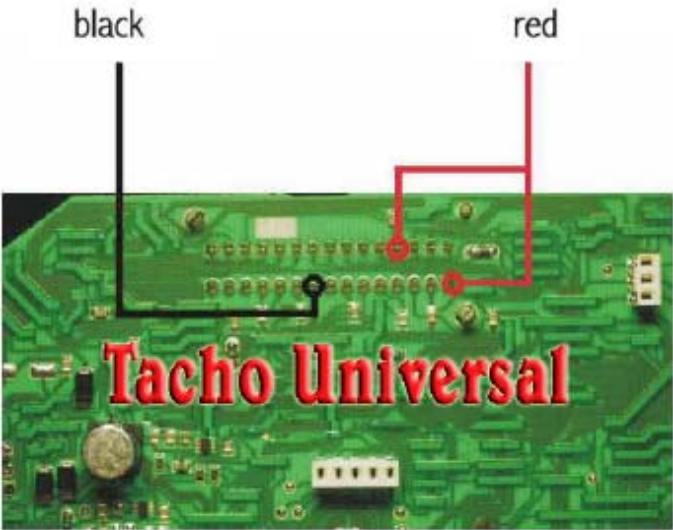
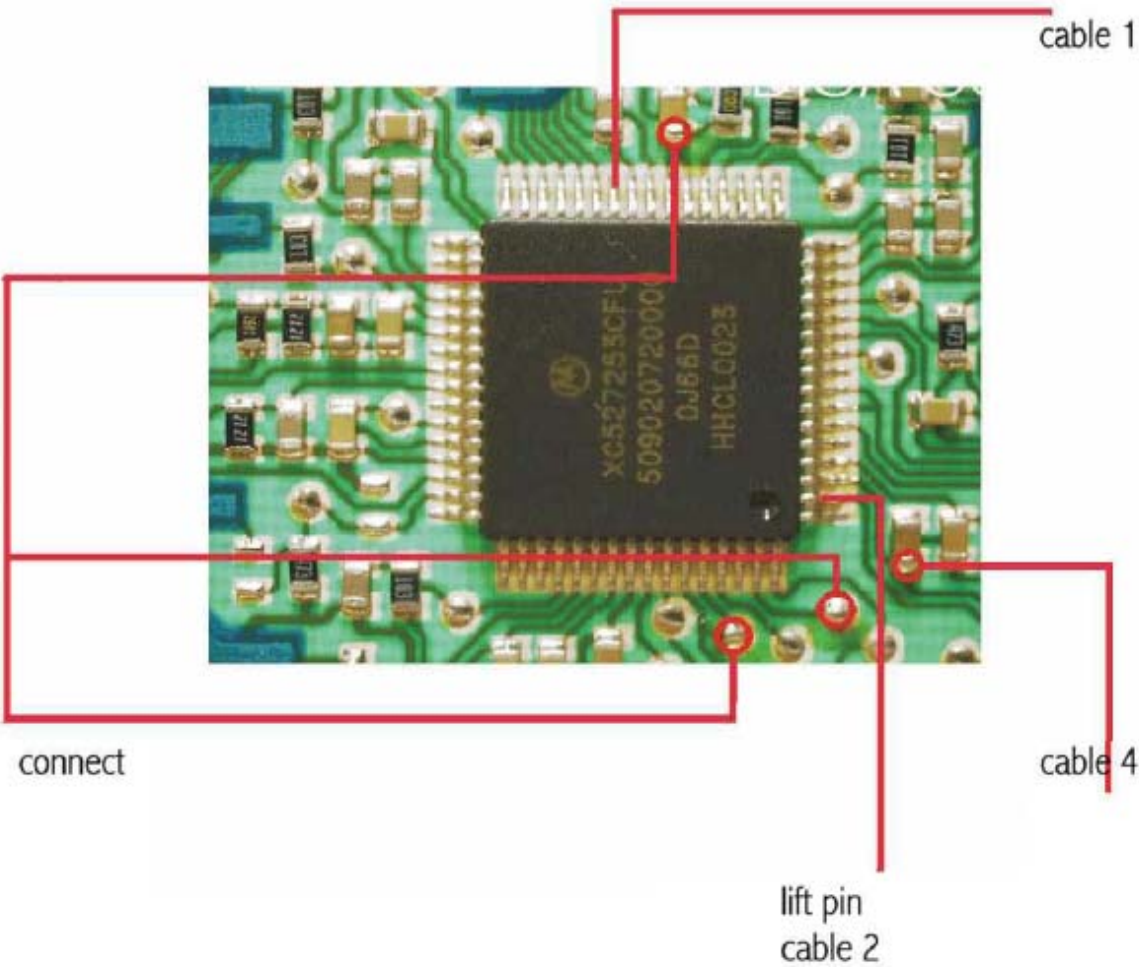

Model Safrane:

Use this board and clip:

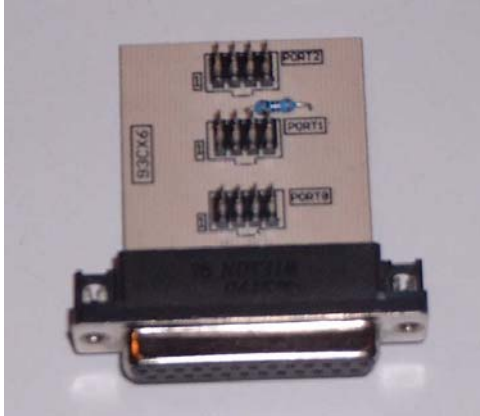

- Remove the cluster and open it.
- Look for the 8 pin chip 93C46 oder 93C56.
- Look for the silver chrystal and join its contacts.
- Connect the clip to port 1.
- Put the clip on the chip 93C46 oder 93 C56 (red on pin 1).
- Select the menu **Renault Safrane- Safrane C46 V1**
or **Safrane C46 V2**
or **Safrane C56**
or **Safrane Mod 99**
- The Tacho Universal shows you the old value.
- Select the menu **Adjust KM.**
- Enter the new value.
- Verify the new value with **OK.**

Model Twingo

Use the Alfa 145/146/Twingo-Plug:

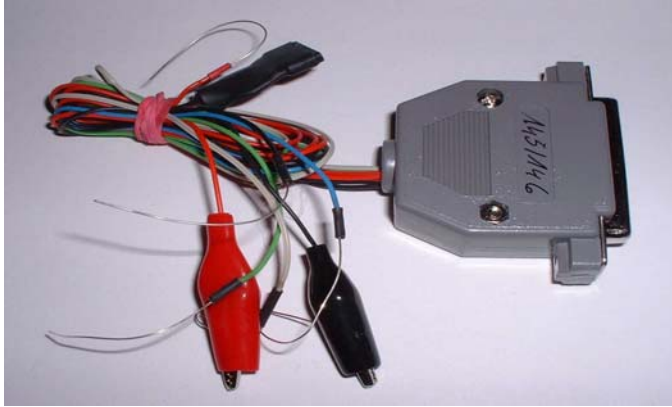

- Remove the cluster and open it.
- Lift the pin for the red cable.
- Connect the cables as shown in the picture.
- Connect the power plug to the 15pin port. Red on pin 1.
- Connect the plug with the Tacho Universal.
- Select the menu: **Renault-Twingo-Twingo VDO**
or **Twingo Borg**

Warning:

Ensure you use the correct program version!

- The Tacho Universal shows you the old value.
- Enter the new value.
- Verify the new value with **OK**.

TWINGO

VDO & BORG

